



Neptune Bath Lift

Instructions for use

CONTENTS

1. INTRODUCTION	5
2. CONTACT INFORMATION	5
3. PRODUCT DESCRIPTION	6
3.1 Environment	6
3.2 Intended User Group	6
3.3 Intended Use	6
3.4 Indications	6
3.5 Product Overview	7
3.6 Features	7
4. SAFETY	8
4.1 Warnings & Cautions	8
4.2 Risk Assessment	8
4.3 Contraindications	8
4.4 Bath Lift Loading	9
4.5 Training	9
4.6 General Warnings	10
5. TRANSPORT & STORAGE	11*
6. SYMBOL DEFINITION	12
7. PARTS IDENTIFICATION	14
8. INSTALLATION & PREPARING FOR USE	16*
8.1 Charging the Battery	16*
8.2 Assembly & Installation	18*
8.3 Applying Side Flap Protectors (Baths with Handles)	21*
8.4 Checking the Bath Lift	22*
9. FITTING ACCESSORIES	23*
9.1 Pelvic Harness	23*
9.2 Extension Kits for Side Flap Protectors	24*
9.3 Cushioned Covers	24*
9.4 Slide & Swivel Aid	25*
10. OPERATION OF THE BATH LIFT	26
10.1 Operational Limits	26
10.2 Electrical Operation	26
11. DISASSEMBLY & REMOVAL	28*
11.1 Detaching the Seat Section	28*
11.2 Removing the Base Section	28*
12. DECONTAMINATION	29*
12.1 General Decontamination Guidelines	29*



Warning

* Highlighted pages are for competent persons only. If in doubt, contact Drive DeVilbiss Healthcare Ltd. or your local distributor.

12.2 Manual Cleaning & Disinfection Guidelines.....	30*
13. MAINTENANCE & SERVICING.....	31*
13.1 General Inspection.....	31*
13.2 Fault Finding.....	32*
13.3 General Maintenance & Servicing.....	33*
14. DISPOSAL OF PARTS.....	34
15. ELECTROMAGNETIC COMPATIBILITY (EMC).....	35
16. SPECIFICATION.....	36
16.1 Bath Lift Data.....	36
16.2 Electrical Data.....	37
17. ACCESSORIES & SPARE PARTS.....	38
18. WARRANTY.....	39

1. INTRODUCTION

Thank you for purchasing this product. These instructions for use should be read carefully before operating the bath lift. Please ensure that you understand all instructions. Contact Drive DeVilbiss Healthcare Ltd. or check our website for the latest version of this document. Users with visual, reading or cognitive disabilities should seek advice from a professional care provider for an appropriate format of this document. If this is not viable, users should contact their provider or Drive DeVilbiss Healthcare Ltd. If you have any questions concerning the operation or maintenance of the bath lift, please contact your provider / supplier who can provide you with expert professional advice.

2. CONTACT INFORMATION

For assistance in setting up, using, maintaining your bath lift, to report unexpected operation or for any service, warranty, sales or customer service information regarding this product, please contact your provider. If in doubt, contact Drive DeVilbiss Healthcare Ltd. at the following address:

Drive DeVilbiss Healthcare Ltd.
Sidhil Business Park
Holmfield, Halifax
West Yorkshire
HX2 9TN
United Kingdom

If a serious incident occurs in relation to the product, reports should be forwarded to the manufacturer and local competent authority.

Please quote the product serial code on all correspondence. The serial code for the bath lift can be found on the identification label, which is behind the backrest.

Service & Maintenance

Tel: +44 (0)1422 233136

Fax: +44 (0)1422 233010

info@drivedevilbiss.co.uk

www.drivedevilbiss.co.uk

Spares

Tel: +44 (0)1274 475125

Customer Service

Tel: +44 (0) 845 0600 333

Fax: +44 (0) 845 0600 334

For Service & Support outside the United Kingdom, please contact the local distribution company from where this equipment was purchased. Failure to do so may result in the product warranty becoming void.

3. PRODUCT DESCRIPTION

3.1 Environment

The Drive Neptune bath lift is intended for use in the following environments:

- a domestic area
- a long-term care area where medical supervision is required and monitoring is provided for multiple users if necessary (e.g. rehabilitation facilities).

3.2 Intended User Group

The Drive Neptune bath lift is intended for a single user of weight up to 160 kg (25 st). Lower (or upper) age limit is not defined, as it depends on the physical size of the user. Professional users and lay users are intended to operate the bath lift.

3.3 Intended Use

The intended use of the bath lift is to support the weight of an individual user, as defined in section 3.2, while bathing, and to assist the user in gaining and maintaining a suitable position.

The bath lift is intended to support a single adult. A risk assessment must always be performed on the suitability of the user to the bath lift and any ancillary accessories.

3.4 Indications

To assist in the raising and lowering of an individual, when used in the environments specified in section 3.1.

3.5 Product Overview

The Drive Neptune is a lightweight, battery-powered bath lift. The bath lift seat is made of glass-filled polypropylene. The base frame is aluminium casting which is coated with electrostatically deposited polyester. The tubes are made of anodised aluminium, the hand control and battery are made of ABS, and the handset button cover is made of a thermoplastic elastomer.

The bath lift is supplied in two parts — a seat section slots into the brackets of the base section. The two main parts can be separated by lifting the seat from its guide pipes.

The bath lift has four suction cups attached to the base plate, which allow it to be securely attached to the bath while in operation. There are two side flaps, one on each side of the base section to allow smooth movement over the edge of the bath.

The bath lift is operated electrically via the battery operated hand control. The handset is connected to the actuator assembly and provides full control to the user/carer operating the bath lift. The controls allow it to move up and down. The battery is charged by plugging into the mains supply when disconnected from the bath lift, then used to operate the bath lift once reconnected.

The bath lift has a safe working load of 160 kg. A range of accessories (see section 17) is available to adapt the bath lift to the user's need as per the carer's discretion.

3.6 Features

- Electrically operated seat with height adjustment
- Removable hand control with a battery indicator light
- Waterproof, floating hand control
- Two-button operation to raise / lower the seat
- Suction pads on the base and battery
- Side flaps to help users getting in / out of the bath
- Side flap diverters supplied to improve movement over bath handles
- Lifting bar for easy release of suction cups
- Additional suction cups available for uneven bath surfaces (see section 17)

4. SAFETY

4.1 Warnings & Cautions



Warning

Warnings in this user manual highlight potential hazards that if disregarded could lead to injury or death.



Caution

Cautions in this user manual highlight potential hazards that if disregarded could lead to equipment damage or failure.

4.2 Risk Assessment

Before using the bath lift, a risk assessment must be performed by a competent individual to ensure the safe use of the bath lift on a user-by-user basis. It is the responsibility of carers and independent users to determine that they are both mentally and physically capable of operating the handset (and in doing so, using the bath lift) with minimal risk of injury to themselves or others.

The risk assessment should include, but not be limited to:

- Entrapment
- Falling out of the bath lift
- Small adults (and children)
- Individuals (and carers) who lack capacity
- Users with visual, reading or cognitive disabilities
- Very active occupants
- Unauthorised people with access to the bath lift
- Submersing under water

4.3 Contraindications

The individual occupying the bath lift exceeding the maximum weight indicated in section 4.4 is a contraindication.

Other contraindications may be relevant which are specific to an individual or care environment.

4.4 Bath Lift Loading

Neptune Bath Lift Safe Working Load: 160 kg (25 stone)

Safe Working Load is the sum of:

- User mass
- Bath lift mass
- Mass of accessories



Warning

- The maximum load shown above is for the bath lift to be occupied by one person only. Additional weight could damage components or destabilise the bath lift, potentially causing injury.
- The bath lift may only be used to assist one person getting in and out of a bath at a time. It should not be used for climbing, or as a support or lifting platform outside of the bath. The backrest is not designed to support an entire person's body weight, and the side flaps are not designed to support other individuals sitting / leaning — risk of bath lift collapse, entrapment.
- The bath lift is not a toy and children should not be allowed to play with the bath lift, as they are at risk of harm.

4.5 Training

All individuals operating the bath lift are to be suitably familiar with the functionality and limitations prior to use. Users with carers are to be familiarised with handset and bath lift functionality by the carers at the earliest opportunity, ideally before using the product.

It is the responsibility of the user to ensure they are suitably trained to use the bath lift and any associated accessories safely and correctly. If these instructions for use are not deemed sufficient and the need for training is required, please contact Drive DeVilbiss Healthcare Ltd. or your local provider (see section 2) who can discuss training options with you.

4.6 General Warnings



Warning

- Do not use a damaged or badly worn bath lift — risk of harm.
- The bath lift is to be installed and put into service following the information provided in these instructions for use. Any serious incident that has occurred in relation to the device should be reported to Drive DeVilbiss Healthcare Ltd.
- The bath lift is designed for occupants do not exceed the safe working load of 160kg; overloading may put the user at risk of falling or entrapment.
- The bath lift is designed to withstand a vertical load. Do not lean against the bath lift once installed, especially the backrest — the suction cups may release and put users at risk of falling.
- The operator must not touch any exposed contacts or connectors while using the product or while in contact with other individuals.
- Misused electrical equipment can be hazardous.
- Take care when using emollients — surfaces may be slippery.
- Accessories that have not been approved or designed for use with the bath lift are not be used — a hazard could be introduced due to product combination incompatibility.
- Modification of the bath lift is not allowed without the permission of Drive DeVilbiss Healthcare Ltd. — a hazard may be introduced.
- The bath lift is electrically operated, so should not be used in the presence of flammable gasses or used in oxygen-rich environments — risk of explosion / fire.
- Keep the bath lift away from sources of heat and naked flames (cigarettes, electric fires, fan heaters etc.) — explosion / fire risk.
- Individuals unable to take a bath without assistance or supervision must not use the bath lift without such supervision. Unsupervised use of the bath lift must be avoided if there is any doubt about the ability of an individual to operate the bath lift safely.
- If the bath lift is to be used by a disabled person living on their own, then a communication device (e.g. personal alarm system) shall be installed in the area of use, so that users can summon assistance in the event of an emergency.
- Do not reach between the seat and the base sections once attached — risk of entrapment.
- If children, adults with learning difficulties or pets pose a potential risk of tampering with the bath lift, its suitability for use is to be considered during the initial user / product risk assessment.
- Ensure the handset cable is free from moving parts and is not under excessive tension to avoid cable damage — damaged cables can create an electrocution / fire risk.

5. TRANSPORT & STORAGE

These conditions should be followed when transporting and storing the bath lift:

- The bath lift should be stored on a flat and level floor.
- The bath lift should be set to its lowest height.
- The bath lift should be covered to protect from fluid ingress, dirt, dust etc.
- Bath lifts should not be stacked atop each other, or stored on their backs. Store upright against a wall, or laid on its side.
- Transport clips and instructions for use should be retained with the bath lift.
- When not in use, wrap the cable around the top of both tubes and tuck the handset in the cable coil with the green cover facing the backrest.



(See image below.) The hand control should only be disconnected from the bath lift when in dry conditions.

Environmental conditions for transport and storage:

Ambient temperature: -10°C to +40°C
Relative humidity: 10% - 90%
Atmospheric pressure: 73 kPa to 125 kPa













Warning

To prevent the risk of cross infection, prior to removal, transport or storage, ensure the bath lift has been cleaned and disinfected in line with section 12 of these instructions for use. Ensure that disposable gloves are used for all decontamination activities and that they are then discarded appropriately, unless the bath lift and ancillary parts have been suitably cleaned and disinfected.

6. SYMBOL DEFINITION

The following symbols are found on this bath lift:

Symbol	Description
	Warning Beware of potential hazard
	Caution Beware of potential product damage
	Refer to instructions for use - Recommended Failure to read the instructions for use could introduce a hazard
	Refer to instructions for use - Mandatory Failure to read the instructions for use could introduce a hazard
	Safe working load Refer to section 4.4
	Temperature limit Refer to section 16.2
	Humidity limitation Refer to section 16.2
	Atmospheric pressure limitation Refer to section 16.2
	Remove battery from cradles when not in use to avoid discharge
	Manual cleaning and disinfection Refer to section 12
	Battery status indicator

Symbol**Description**

Battery output
Refer to section 16.2



Direct current



Medical Device



Type BF applied part

Applied Part: The parts of the bath lift that come into physical contact with the user / occupant for the bath lift to carry out its intended function (refer to section 16.2 for a list of applied parts).

Type BF: Applied parts where the patient connections are isolated from other parts of the medical electrical equipment - Complying with specific requirements for protection against electric shock to EN 60601-1



Serial number



Catalogue number



Date of manufacture



Manufacturer



W.E.E Label - Found on individual parts of electrical system (Waste Electrical and Electronic Equipment) Refer to section 14

IPX6

The cable connectors of the bath lift are protected against water spraying.

IPX7

The battery and handset are protected against water immersion to 1 metre depth.



Take care — surface may be hot to touch



Model number

7. PARTS IDENTIFICATION

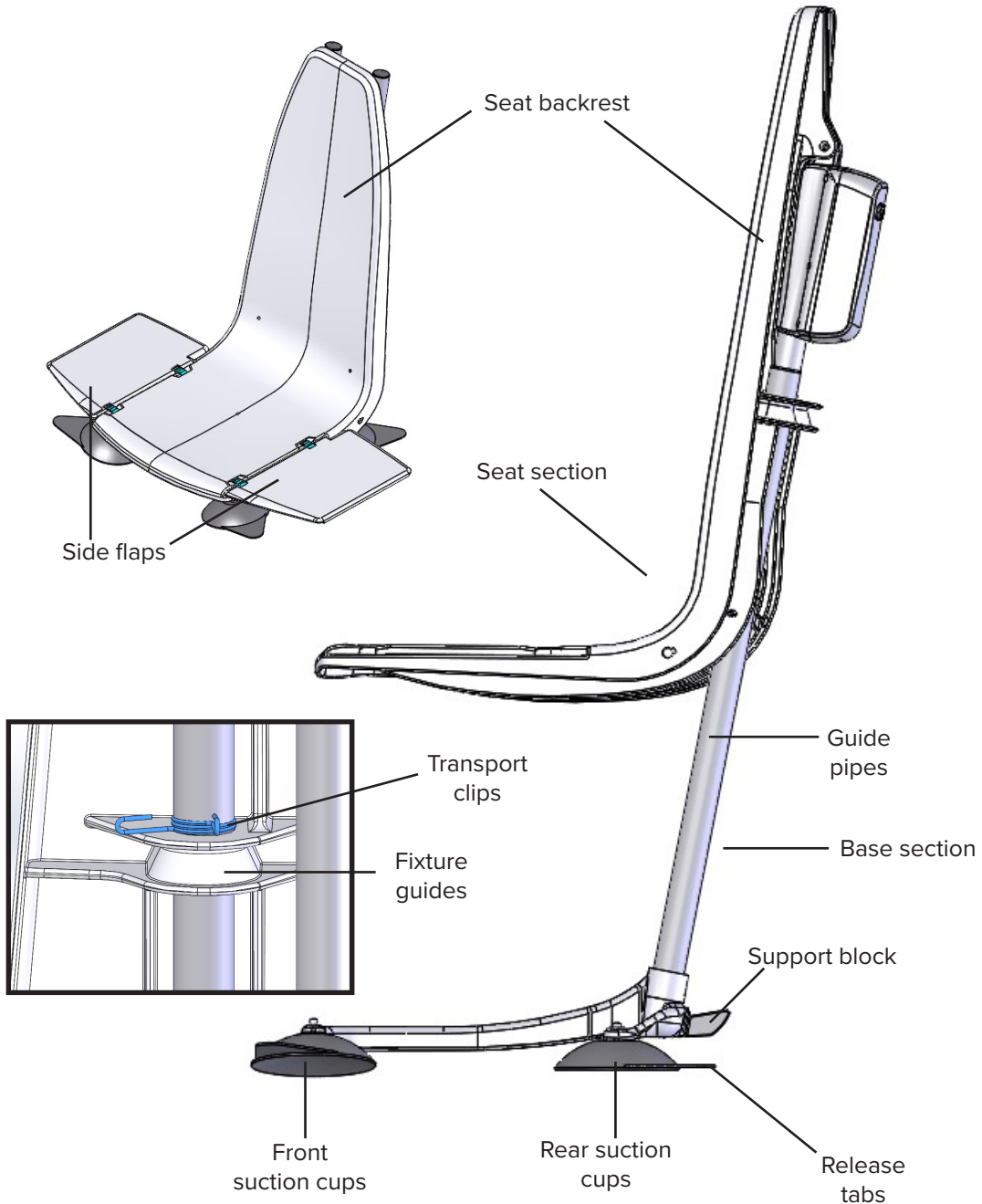

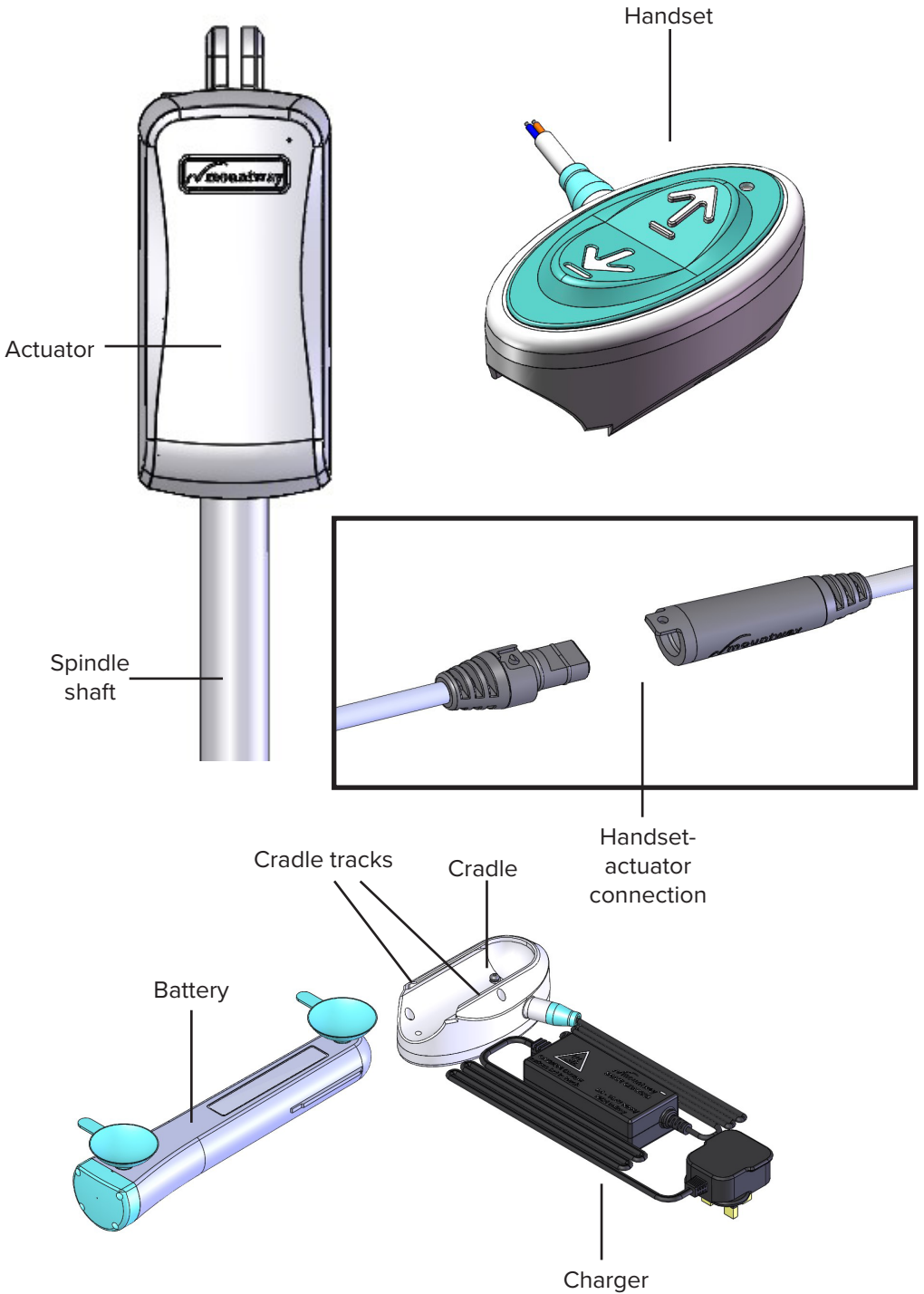

8. INSTALLATION & PREPARING FOR USE



Warning

- Before attempting to assemble the bath lift, ensure these instructions have been read and fully understood.
- Only assemble the bath lift before submersing it under water – risk of electric shock.
- Only competent persons are to assemble and prepare the bath lift for use. If in doubt, contact Drive DeVilbiss Healthcare Ltd. or your local distributor.
- Ensure a risk assessment in line with local health and safety policy is undertaken to ensure that staff are not put at risk when performing assembly activities.

8.1 Charging the Battery

Before you first use your bath lift, or after long periods of non-use (at least 7 days), remove your battery from any packaging and charge it fully. If the battery is already connected to the handset, disconnect the cable.



Warning

- Do not open the battery.
- Do not charge your battery inside the bathroom.
- Ensure the battery is not exposed to direct sunlight or a secondary heat source – direct heating of the battery via an external source could pose a risk of fire or cause an explosion.
- The charger box may get hot when in use. Take care when handling.



Caution

- Only use the Drive Neptune Bath Lift with the hand control and charging parts supplied. Never charge the battery using a different charger.
- Charge your battery indoors, on a hard, flat surface at normal room temperature. Do not cover the battery or charge in humid conditions.
- Ensure the battery has one full charge and discharge cycle every three months to maintain the charging capability.
- Ensure that no metal objects touch the contacts on the battery, as this will damage the battery.

Slide the battery into the track on the charging cradle until it clicks into place (see figure below). Plug the charging cable into a mains socket outside the bathroom and switch on the electricity supply. Always use the plug in an accessible location, so that it is not difficult to disconnect.

Note: The battery functions may stop operating without warning once the battery charge is depleted. Return to mains supply as soon as possible.

The light on the charger box will initially flash in a quick sequence: BLUE, GREEN, BLUE, GREEN, before a constant BLUE light, indicating the battery is charging. When the battery has been fully charged, the BLUE light on the charger box turns to a constant GREEN — the battery is ready for use and can remain charging until using the Neptune.

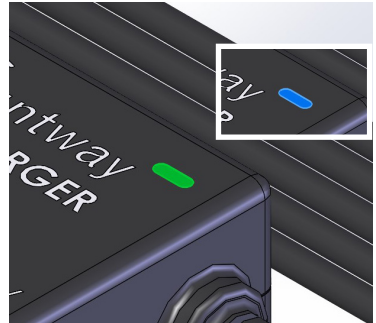
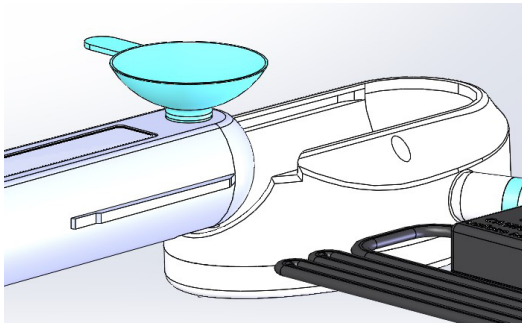

Caution

When not charging, disconnect the charger from the mains, and disconnect the battery from the charging cradle to prevent the battery discharging.

With regular use, Drive DeVilbiss Healthcare Ltd. recommends charging the battery after each bath wherever possible, or leaving it on charge until your next bath. The battery should have at least one full charge and discharge every three months to preserve its life. The battery cannot be overcharged.

For any concerns about the electrical parts, see section 13.2 for fault finding, contact Drive DeVilbiss Ltd. (section 2) or contact your provider.

Note: If the HANDSET is FLASHING RED, please stop operating the bath lift and recharge your battery as soon as possible.

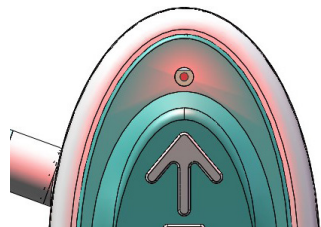

The tables below show the lighting modes of the charger and hand control according to the indicator lights. Any other signals may indicate faulty equipment. For any concerns about the electrical parts or indicators, see section 13.2 for fault finding, contact Drive DeVilbiss Ltd. (section 2) or contact your provider.

Charger indicator	Status
FLASHING (BLUE, GREEN, BLUE, GREEN)	Mains supply connected.
Constant BLUE	Charging.
Constant GREEN	Fully charged.
None	Not charging. Check connection or try another charger.

Hand control indicator	Status
Constant GREEN	In use. Battery level okay.
FLASHING GREEN	Low battery. Recharge after use.
FLASHING RED during use	Very low battery. Recharge immediately.
None	Not charging. Check connection or try another charger.

8.2 Assembly & Installation



Warning

- To avoid entrapment risks or detachment of parts when moving the bath lift, we recommend assembling inside the bath, where it is due to be installed. If assembled elsewhere for any reason, ensure the base is on a flat, hard surface in a safe environment.
- Take care not to rotate the bath lift when lifting — risk of harm from falling parts (e.g. handset, seat section).
- Ensure both side flaps lean against the bath — entrapment risk.
- Do not install the bath lift on a step or large dip — instability risk.
- When installing your bath lift, place it at the opposite end to the taps to avoid risk of harm from extreme tap water temperatures.
- Please ensure your bathtub is clean and dry before installing your bath lift — risk of contamination.



Caution

- Always remove the transport clips before use and keep them aside for when the bath lift is stored or transported. Failure to do so may damage moving parts.
- Avoid placing the bath lift in direct sunlight — direct sunlight could damage the electrical system and / or cause fading of the labelling.
- Do not lift the bath lift or its seat section via the actuator assembly — damage risk.

Remove the bath lift from the packaging, carrying the bath lift from the base section. If the seat and base sections are packaged separately, remove one part at a time.

Turn the bath lift face-down on the floor. Remove any transport clips from the pipe guides behind the bath lift. Keep them with the bath lift for future transport and storage. If the seat and base sections are attached, hold the base frame and pull gently towards you until the aluminium tubes slide out of the upper and lower holes behind the backrest.

The seat should slide away smoothly — if there is resistance, check for fasteners or obstructions. Place the seat carefully on its side and lift the detached base section into the bath, with the suction pads facing down. Push the base down on a flat area, facing forwards with the support block as close as possible to the back

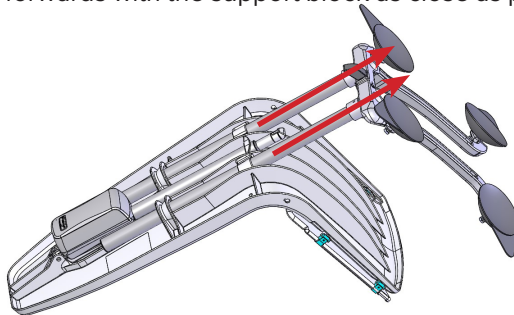

of the bath. Moisten the suction cups to aid adhesion.

Note: Both side flaps should lean on the inside of the bath when extended, the seat should be able to rise to the top of the bath, and all suction cups should fit securely to the floor. The internal depth of the bath should be below 435 mm, the length above 495 mm and the width between 360-710 mm. See section 16.1 for dimensions of the bath lift. If the side flaps are not wide enough for your bath, contact your supplier to purchase the 'Corner & Wide Bath Kit' (section 17). Once bought, 95 mm can be added to the width of the side flaps.

All four of the suction cups should be stuck securely to the base of the bath. Some baths have dimples or ripples, which generally appear up to halfway across the bath. Re-enameled or textured baths may also cause issues. Check your suction feet before every bath and clean away any residue from the suction cups.

The actuator assembly should be attached securely; to attach the actuator assembly, lie it against the backrest, slotting the shaft through the large hole at the bottom of the seat. Then align the holes at the top of the actuator with the holes on the backrest. Push the snap pin through all of the locating holes to secure the actuator.



Warning

- Failure to connect the seat and base sections properly may result in a detachment, which puts the user / operator at risk of injury.
- The suction cups are self-locking. When installing the base section, ensure the suction cups are sticking securely to the bottom of the bath. The suction cups do not adhere to bath mats. Failure to secure the bath lift poses an instability risk. If you need to purchase additional suction cups for safe and secure adhesion to the bath, contact Drive DeVilbiss Healthcare Ltd. or your supplier.
- Ensure the actuator assembly is fully secure before assembling or using any controls. Improper use may result in a detachment or cause damage, which puts users at risk of injury from loose parts. If there is no motion, see section 13.2 for actuator issues.
- Ensure that handset connection and actuator casing are high enough to not be submersed under water — risk of inadvertent operation or electric shock.
- Consideration is to be taken in the positioning of the bath lift, charger and handset cables to minimise the risk of accidental entanglement or strangulation.

If the base section is secure, lift the seat section over the base, folding the side flaps inward. Slot the pipes into their fixture guides. The spindle shaft of the actuator should fit into a socket in the base frame.

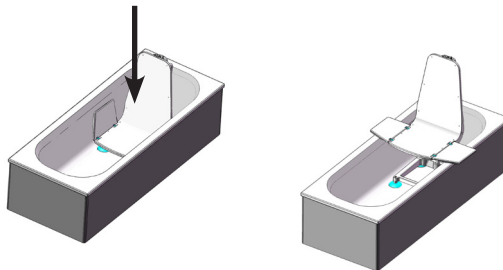

When the seat section is correctly fitted and stable, connect the handset and actuator cables, pushing the sockets until they lock into place. Put the handset in a safe position. Slide the fully charged battery into the tracks on the handset until it clicks into place. Push the 'UP' button to test the battery level (see section 8.1). Use the suction cups to attach the handset to a convenient location on the side of the bath. Unfold the side flaps and check they both lean against the inner walls of the bath (or the side flap protectors).

8.3 Applying Side Flap Protectors (Baths with Handles)

If you have handles on your bath, please attach the side flap protectors provided. These are plastic strips used to cover the bath handles and avoid the side flaps getting trapped. (See the images for guidance.)

Extension kits are also available to purchase (section 17), which enable the protectors to be joined together to form a wider area of protection.

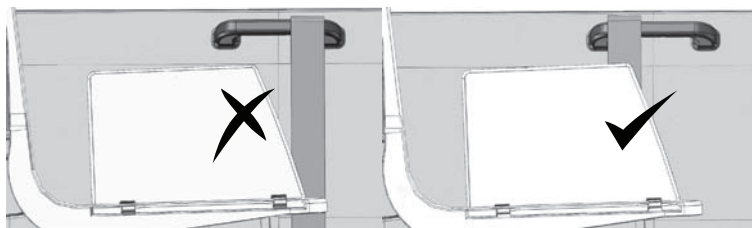

If the bath lift side flaps become trapped under your bath handle,

- STOP the bath lift by releasing the buttons
- Press the 'DOWN' button on your hand control to free the side flap
- Ensure the side flap is no longer trapped under the handle or other obstructions
- Press the 'UP' button on your hand control



Caution

Failure to attach side flap protectors properly may cause obstruction and damage to the mechanism. Move the protectors closer to the bath lift, or move the bath lift forwards if necessary to avoid the side flaps getting caught. Extension kits are also available for purchase if they are more suitable.

8.4 Checking the Bath Lift

The bath lift is now fully assembled. Before it is put into use, ensure the bath lift has been correctly assembled by carrying out the following checks:

- Has the bath been cleared of any residue?
- Are all four corner suction cups on the base section clean, and securely attached to the bottom of the bath?
- Is the actuator held securely into position?
- Is the handset connected securely to the actuator?
- Has the battery been charged sufficiently before use?
- Is the battery fully slotted into the handset, through both tracks?
- Are the battery and actuator high enough to avoid submersion in bath water?
- Do the 'UP' and 'DOWN' controls move the spindle shaft and provide safe upward and downward travel?
- Are both side flaps present? Are any bath handles covered by side flap protectors?
- Has all packaging been removed, e.g. transport clips and loop tape?
- Are the cables free of all moving parts of the bath lift? Is there enough free cable to allow for movement?
- Is the bath lift clear of obstructions? Is there enough space for the occupant to move their arms and legs freely?
- If fitted, are all compatible accessories fully secured?
- Has a risk assessment been performed on the suitability of the bath lift for the user?

9. FITTING ACCESSORIES



Warning

These accessories are not essential for basic functionality, but side flap diverter extension kits may provide essential safety for baths with handles. Ensure all bath lift accessories are attached securely before operating and bathing, to reduce the risk of falling or entrapment.

9.1 Pelvic Harness

These harnesses are available to help maintain body posture and prevent slipping. Each harness has one fixed and one adjustable section, which connect around the user with a buckle. The black adult harness is made of polyester laminated neoprene with nylon fixing bars and straps. The blue child harness has a soft gel strap instead. Each strap section has colour coded tags. Both harnesses can be adjusted to suit the shape and size of the user;

- Adjust the height of the chest (thoracic) harness by placing the strap fixing along the bracket to suit the user's height.
- Adjust the harness lengths by pulling the material through the belt buckle
- Place the shorter parts of the harnesses on the side used to enter / exit the bath, so the buckle is more accessible for release.

Small pelvic harness (5623-0216):

- 1 x fixed section with red tag
- 1 x adjustable section with green and red tags

Large pelvic harness (AB230):

- 1 x fixed section with yellow tag
- 1 x adjustable section with yellow and blue tags

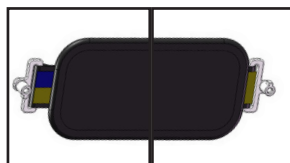

To fit the pelvic harnesses, insert the white strap fixing of the adjustable section (i.e. with 2 colours on the tag) into the seat eyelet on the farthest side from the carer. If using a blue gel harness, ensure the gel is facing inward when attaching the sections. Rotate the strap fixing to lock it into place, and repeat with the fixed section on the near side of the seat.

When the user is seated, place the fixed section over the pelvis and lie the adjustable section over it. Connect the buckle and pull the strap to tighten the harness as required.



Warning

Ensure harnesses are not excessively tight.

9.2 Extension Kits for Side Flap Protectors

First, decide how many side flap protectors you need to support the side flaps, and where you want to join the protector pieces. Non-hooking protectors are available to extend the area of protection beyond the bath handles (as shown).

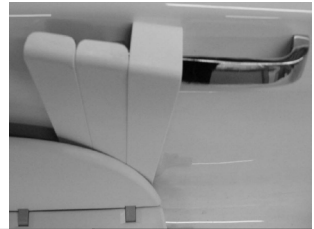

To fit the extension pieces, push the joining clips through the housing underneath, until they click into place. Attach the second protector piece by pushing the clips through the housing, then repeat for additional side protector pieces.

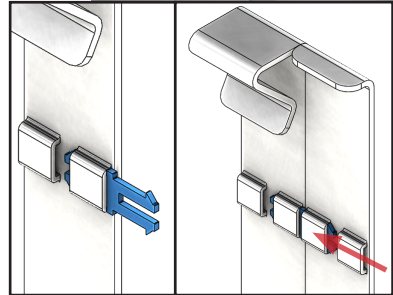

Note: The joining clips may be difficult to remove without a tool, so take care when attaching or removing.



Warning

At least one standard hooked protector part must be used to hook around the bath handle. If loose protectors pose an instability or entrapment risk, hooked protectors should be used to cover the entire length of the handle.

9.3 Cushioned Covers

Note: Both side flaps must be attached to the Neptune seat before fitting the cushioned seat cover. If both covers are being used, fit the backrest first.

If you have a back cover, fit it over the top of the backrest. If you have a seat cover, place it around both side flaps and stretch the securing strap around

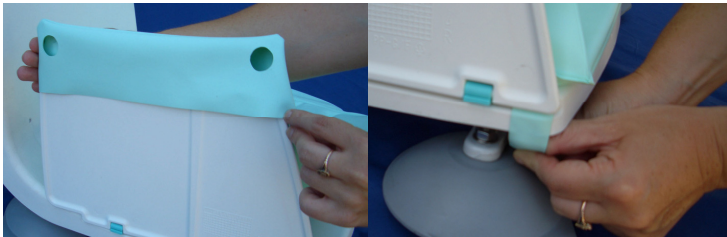

the front of the seat (as shown). It may be easier to do this by folding each flap partly inwards.

Once the cover(s) are applied, insert the screws through the holes in the cushioned seat cover and Neptune backrest. Any back covers should be fixed beneath seat covers. Secure from behind using the nuts provided. Reverse these steps to remove.

Note: Please fit the covers before you bathe. Avoid using accessories which may make it difficult to fit the covers.



Warning

Ensure the mats are secure before using the bath lift — risk of falling.

9.4 Slide & Swivel Aid

The Slide & Swivel Aid allows users to slide and turn into the middle of the seat. The transfer disk supports getting in and out of the bath lift. Place the Slide & Swivel Aid onto the seat, crossing the side flap which passes over the edge of the bath.

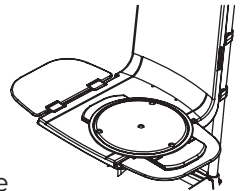

Warning

Take care when moving on the Slide & Swivel Aid — entrapment risk.

10. OPERATION OF THE BATH LIFT

10.1 Operational Limits

- Ambient temperature: 0°C to +40°C
- Relative humidity: 15% - 75%
- Atmospheric pressure: 73 kPa to 106 kPa

10.2 Electrical Operation

The hand control may be operated by either the occupant or carer. Any carer operating the bath lift should make the occupant aware of the action(s) about to take place. Functions are of the 'hold to run' type; pressing and holding the relevant button causes the desired function to operate.

To terminate all operations and stop all movement safely, release the buttons. In the event of an emergency, sliding the battery out of the handset can instantly terminate all bath lift movement.



Warning

- When operating the bath lift, the occupant is expected to be sat in the seat. Operators supervising users should be next to the bath when operating controls. Do not operate the controls while anyone is entering or leaving the bath or bath lift – a hazard may be introduced.
- Before operating the bath lift, ensure the occupant is positioned appropriately and limbs are clear of moving parts to prevent entrapment. Always keep the user's legs stretched forwards when lowering the bath lift, to avoid the risk of entrapment under the seat.
- Always check the water temperature before bathing to avoid the risk of harm from extreme tap water temperatures.



Caution

- Make sure the bath lift functions work correctly before operating, using the checklist in section 8.4 for guidance.
- Always check the mechanism is free of obstructions before use.
- Please ensure the handset and backrest cables are always connected during use.
- When transferring on / off the bath lift, the side flap should always rest flat on the side of the bath.

With the fully charged battery connected to the handset, press and hold the 'UP' button until the seat is level with the top of your bath. The side flaps should be resting flat over the rim of the bath.

Sit on the side flap and place your legs against the bath. Slide or shuffle over to the middle of the seat, lifting each leg into the bath, one at a time. Swivel around so that you are sat in the seat, facing forward in a comfortable bathing position. (Transferring may be easier if the seat and the side flaps are wet first. If users want help with moving in / out of

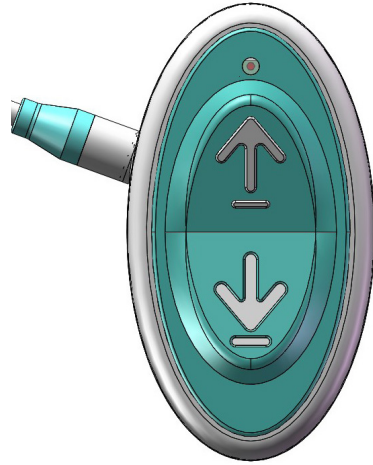

Warning

Take care not to trap body parts in gaps around the bath lift when moving in / out of the seat. Extend the occupant's legs and keep arms above the seat.

the bath, the 'Slide & Swivel' accessory is also available for purchase.)

When ready, press and hold the 'DOWN' button on the handset to lower into the bath. To stop, release the buttons.

When you have finished bathing, press and hold the 'UP' button on the handset until the seat is level with the top of the bath and the side flap is flat. The battery and handset can be released by pulling the tabs on the suction cups.

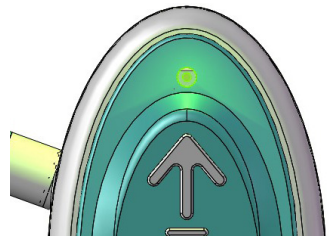

When not in use, lower the seat and wrap the cable around the top of both tubes. Tuck the handset in the cable coil, with the green cover facing the backrest.

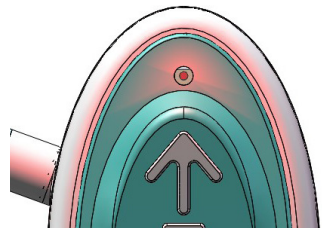

Note: If the HANDSET is FLASHING RED, please stop operating the bath lift and recharge your battery as soon as possible.



Caution

When not in use or charging, disconnect the battery from the charging cradle to prevent the battery discharging.

11. DISASSEMBLY & REMOVAL

11.1 Detaching the Seat Section

- Empty the water from the bath.
- Press the 'DOWN' button on the handset until the seat is in the lowest position
- Fold the two side flaps inward, onto the seat
- Disconnect the battery and place the handset on the seat
- Lift the seat section until clear of the pipe guides

Note: If reassembling the bath lift for storage or transport, ensure transport clips are secured on the guide pipes (see section 7), to prevent the halves from separating.

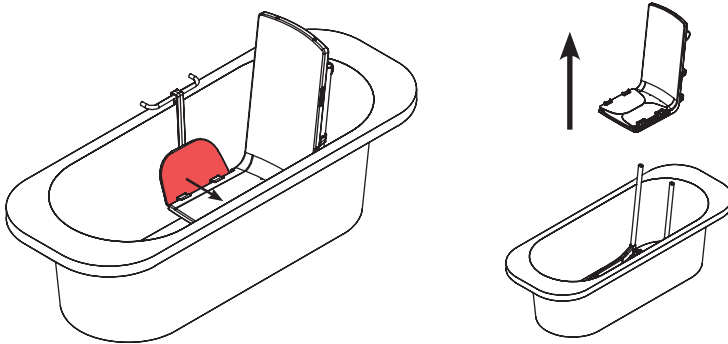

Warning

Do not use the backrest to lift the bath lift. Hold sections from the bottom and carry upright to prevent injury from loose parts.



Caution

Do not lift the seat via the actuator assembly — damage risk.

11.2 Removing the Base Section

Once the battery is disconnected, the seat section may be removed and carried separately. Hold the tubes and pull the suction release tabs from the back. Tilt the frame forwards, release the front suction cups and lift the base out of the bath.

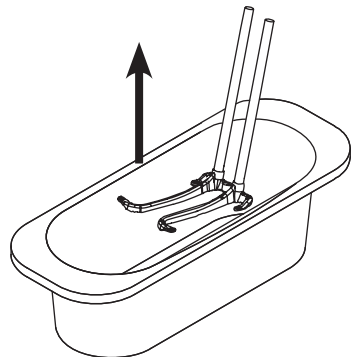

Note: Only disconnect the handset in dry conditions to avoid getting the connectors wet.

12. DECONTAMINATION

12.1 General Decontamination Guidelines



Warning

- Always disconnect the battery from the mains supply and the actuator prior to cleaning or disinfection. If the actuator is removed for cleaning, also disconnect the battery. Keep the handset connected to the bath lift to maintain the IP rating.
- PPE must be worn during manual decontamination to prevent the risk of infection.
- Regular cleaning and disinfection of the bath, bath lift and relevant accessories will help to prevent the risk of cross-infection.
- Clean and disinfect the device and relevant accessories between users to avoid risk of cross-contamination.
- The use of abrasive instruments, abrasive / solvent solutions, neat bleach or similar surface cleaners is not recommended. Damage to cleaned surfaces may also impair the integrity of the lifting structure and put the user at risk of injury.
- Deviating from the specified cleaning instructions could cause a biological hazard, especially in multi-user environments, and adversely affect the life and efficiency of the product.



Caution

- Do not use pressure hoses on the bath lift as they could cause damage to the electrical components.
- Clean residue regularly to prevent degradation and discolouration of the bath lift.
- Do not clean the connection ports.

The bath lift does not require special tools or cleaning fluids for decontamination, and it is not expected to be sterilised. Since the bath lift is made for personal use at home, it can be cleaned with basic household products. The bath lift needs to be cleaned more regularly and thoroughly when bathing more frequently, or when using excessive amounts of bathing oils, creams, emollients and salts. (Residue can be removed with domestic washing-up liquid.) Check that the suction feet still stick to the bath every time before you bathe and ensure that all residues are cleaned away.

Infection control and routine cleaning must be carried out in accordance with your local Infection control policy or regulatory body. Cleaning and disinfection

agents should be used in accordance with their manufacturers' guidelines.

Note: With regular use, we recommend disinfecting the bath lift and accessories after every use. If the bath lift is in a multi-user environment where multiple persons use the bath lift, the bath lift and any accessories must be cleaned and disinfected before different persons use the device.

12.2 Manual Cleaning & Disinfection Guidelines

It is advisable to remove any accessories attached to the bath lift. Remove fitted cushion covers and decontaminate on a regular basis. It is also advisable to clean the bath surface under the suction cups from time to time.

General Cleaning:

- Use a regular household cleaner and a damp cloth. Start with the cleanest parts of the bath lift and systematically move to the dirtiest parts.
- Extra care should be taken around areas where excess dirt or dust may gather. The cloth should be changed during the cleaning process if it becomes soiled.
- Wipe down with a clean cloth, moistened with a mild detergent and diluted in warm water (40°C).
- Rinse with cold, clean water and a clean cloth and allow to dry fully before use.

Disinfection:

- Mop up any fluid with paper towels.
- Wipe the bath lift down using cold clean water.
- Wipe down with a 0.1% Chlorine solution (1,000 ppm) in cold water.
- Rinse with cold clean water and a clean cloth and allow to dry fully before use.

In cases of blood spills or other bodily fluids, it is recommended that a 1% Chlorine solution (10,000 ppm) is used instead.

Note: If any of the stages stated above are omitted or combined, the effectiveness of the decontamination may be reduced.

13. MAINTENANCE & SERVICING



Warning

- No maintenance or servicing should be conducted while the device is in use – risk of electric shock, entrapment, loose parts, etc. If not possible due to the occupant's mobility, a risk assessment should be carried out, and if deemed safe to proceed, care should be taken for service engineers to avoid contact with the occupant when working on electrical items.
- Failure to carry out the following checks at the stated frequency could negatively influence the essential performance of the bath lift and as a result put individuals at risk.



Caution

All maintenance on the device specified in this section shall only be done by a competent person. For any maintenance concerns, contact Drive DeVilbiss Healthcare Ltd. or your provider.

13.1 General Inspection

- Users and/or attendants should periodically check the bathlift at least every six months to ensure that:
 - The bath lift operates as per its intended purpose.
 - All necessary parts are present.
 - All fixtures and fittings are tight.
 - The suction cups are in good condition.
 - The moving parts are free from obstruction.
 - No parts show signs of excessive wear.
 - The electrical components display no sign of fault or damage, including the battery – if so, unplug all parts and remove the bath lift from use immediately.
- The bath lift is cleaned and disinfected following the guidelines in these instructions for use.

If the bathlift is operated by a paid attendant or employee then it is classed as work equipment and will be subject to LOLER requirements. This does not apply if the device is solely operated by the user or an unpaid attendant (for example a family carer).

LOLER states that all lifting equipment used for lifting people should be thoroughly examined at six monthly intervals and all examination records are

retained for inspection. If there are any signs of damage, or the bath lift is not performing as it should, withdraw it from service until the bath lift has been repaired and is fit for use.

13.2 Fault Finding

Listed below are a set of electrical faults that may occur within the service life of the bath lift. If a fault does occur, please try the following suggestions, as these may help in diagnosing the fault.

If a specific part of the device seems to be faulty, use a replacement part. Order codes to purchase replaceable parts are in section 17.

Fault	Possible cause	Remedy
Electrical function(s) do not work	Battery / handset not connected	Check plug connection between handset and actuator is secure. Insert battery into both tracks of the cradle and slide until it clicks into place.
	Battery level low	If the indicator light on the HANDSET is FLASHING RED, recharge the battery. Remove battery from cradle between uses.
	Heavy load on the bath lift	Remove load. Review loading restrictions in section 4.4.
	Damage to electrical components	If the indicator light on the HANDSET is FLASHING RED during use, recharge the handset. The charger light should be RED when charging. If not, unplug the device and contact an approved service engineer.
Handset light is RED, bath lift only moves up	Battery level low	Charge battery immediately and check for obstruction. Stop Descent™ prevents bath lift lowering so users can leave the bath.
Electrical functions working slowly or intermittently	Battery level low	Charge battery immediately. Remove battery from cradle between uses.
	Heavy load on the bath lift	No corrective action required – check that the load on the bath lift does not exceed the safe working load.
	Damage to electrical component(s)	Check the handset is working and the battery has been charged in the past 7 days. If the issue persists, or there is no GREEN light on the HANDSET, contact an approved service engineer.

Battery not charging	Battery not connected	Insert battery into both tracks of the charger cradle and slide until it clicks into place. The indicator light on the charging box flashes when connected to the mains, and shows a RED light when charging. When using the handset, insert the battery through both tracks fully.
	Damage to electrical component(s)	Check the handset works as above. Try another mains socket, or replace faulty parts with any spares available. If the issue persists, contact an approved service engineer.
Bath lift unstable	Suction feet do not stick to bath surface	Moisten the suction cups and apply all four on a clean bath surface. DO NOT use over mats, steps, or rippled or textured surfaces. Any worn or damaged suction cups should be replaced.
	Bath lift tips in highest position	Suction cups stabilise bath lift when attached securely to the floor of the bath. Move the seat to the lowest position when not in use. When removed from the bath, the bath lift should be ideally leant against a wall, or laid on its side.

13.3 General Maintenance & Servicing

Only authorised service personnel or Drive DeVilbiss Healthcare service personnel should carry out repairs or service activities. Refer to the service manual for part codes and assembly detail. Copies are available from Drive DeVilbiss Healthcare Ltd. Contact details can be found in section 2.

For Service & Support outside the United Kingdom, please contact the local distribution company from where this equipment was purchased. Failure to do so may result in the manufacturer's warranty becoming void. **The bath lift must be serviced once yearly, as a minimum.**



Warning

- Always disconnect the bath lift from the main power supply prior to performing any maintenance procedures (where viable).
- Modification of the bath lift is not allowed without the permission of Drive DeVilbiss Healthcare Ltd.
- Never attempt to deconstruct the enclosures, re-wire any components or replace internal battery components. Electrical system components are only to be replaced by authorised service personnel or a Drive DeVilbiss Healthcare Ltd. service engineer.

14. DISPOSAL OF PARTS

When the bath lift, the electrical system or any associated packaging and accessories have come to the end of their useful life, follow local recycling and W.E.E.E. (Waste Electrical and Electronic Equipment) policies for disposal.

Individual parts can be separated and disposed according to the type of material. The electrical components of the bath lift should not be disposed in municipal waste. Some of these electrical components could be harmful to the environment and where viable, can be recovered and reused / recycled. The plastic and metal parts of the bath lift (including the suction feet) can also be recycled at appropriate recycling centres for the respective materials.

When the bath lift is unpacked for the first time, the cardboard box, plastic bags and polystyrene materials used for the bath lift packaging can be recycled at recycling centres that offer suitable cardboard and polymer recycling programmes.

For further information about disposal, contact Drive DeVilbiss Healthcare Ltd. (see section 2).



Warning

The bath lift and any associated accessories are to be decontaminated before disposal to avoid the risk of cross-contamination.

15. ELECTROMAGNETIC COMPATIBILITY (EMC)

The bath lift's electrical system has been designed to meet the EMC requirements of EN 60601-1-2. However, it may still be affected by or emit harmful radio frequency (RF) energy. The RF emissions from the electrical system are very low and are not likely to cause any interference to nearby electronic equipment, but interference to sensitive equipment is still possible. Likewise, if the immunity limits of the electrical system are exceeded, the system may be seen to operate abnormally.

If the bath lift or any alternative equipment is found to be operating abnormally, turn off the piece of equipment that is believed to be causing the interference (if possible) to identify the source of the RF energy. Once identified, mitigation measures are to be taken, such as the separation distances being increased and / or the device(s) being re-orientated.

If the bath lift continues to operate abnormally, turn off at the mains supply and contact Drive DeVilbiss Healthcare Ltd. (see section 2) or your local distributor.

For specific emissions and immunity information relating to the bath lift, contact Drive DeVilbiss Healthcare Ltd. or your local distributor.



Warning

- The bath lift should not be used adjacent to or stacked with other equipment where possible. If adjacent or stacked use is necessary, the bath lift should be observed to verify normal electrical operation in the configuration in which it is to be used.
- Use of accessories and cables other than those specified or provided by Drive DeVilbiss Healthcare Ltd. could result in increased electromagnetic emissions or decreased electromagnetic immunity of the bath lift and result in improper operation.
- Portable RF communications equipment (including peripherals such as antenna cables and external antennas) should be used no closer than 30 cm to any part of the bath lift (including its cables), otherwise a degradation in performance could result.

16. SPECIFICATION

16.1 Bath Lift Data

Product code: NEPA

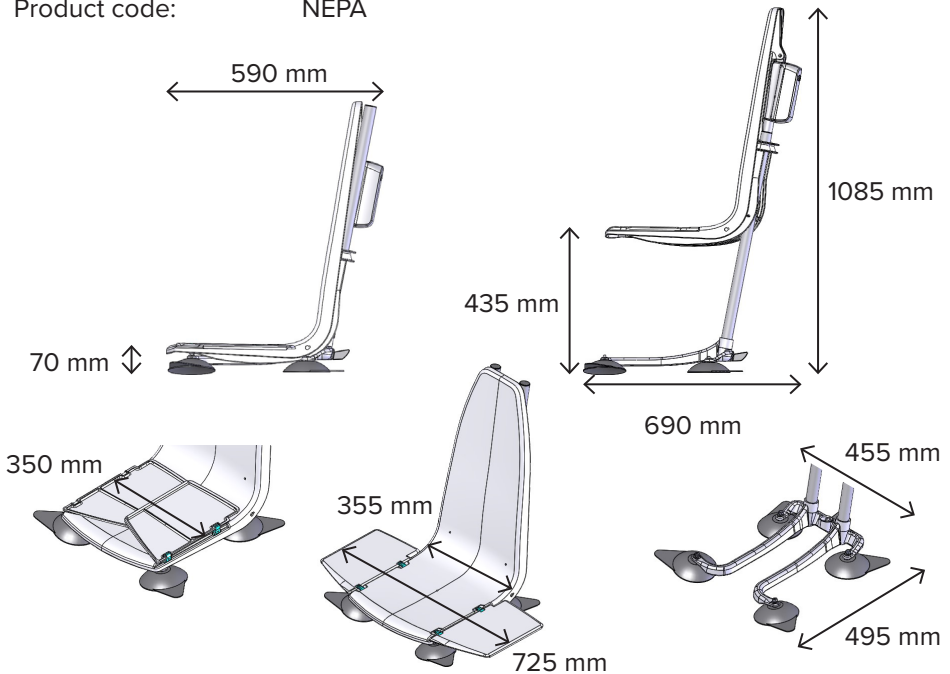

Dimensions may vary with orientation of suction cups.

Actuator stroke: 0 - 375 mm

Operating forces: ~11N

Safe working load: 160 kg (25 stone)

Product weight: 9.2 kg – Bath lift without battery (inc. 0.15 kg hand ctrl)
0.4 kg – Battery
0.4 kg – Charger

Duration of stroke: Approx. 50 seconds up, 30 seconds down (80 kg load)

Application environment: Intended for indoor use only. See section 3.1

The bath lift parts and accessories are manufactured using various materials. For information about materials, contact Drive DeVilbiss Healthcare Ltd. (see section 2).

16.2 Electrical Data

Mains input:	100–240 V, ~ 50–60 Hz, 30 W, 0.5 A max
Battery input:	14.4 V, DC, 1.0 A max
Battery output:	14.4 V, DC, 7.0 A max
Duty cycle*:	10% max (non-continuous operation) One cycle max within 20 minutes.

* Electrically operated bath lifts are intended to be operated intermittently rather than continuously. If the bath lift is operated continuously for up to 2 minutes, it must then be left for at least 18 minutes before reuse to allow the electrical system to cool sufficiently. If the bath lift is used continuously for an extended time, and it exceeds the duty cycle, the actuator may become temporarily disabled or irreparably damaged.

Battery type: Nickel-Metal Hydride (Ni-MH)

Battery UN number: UN3496

Safety standards: EN 60601-1
EN 60601-1-11
EN 10535

Electrical shock protection: Type BF

Applied parts: Bath lift seat section
Battery
Handset

Liquid ingress protection: IPX6 – Jet resistant (Actuator, cable connectors)
IPX7 – Submersible to 1 m
(Battery, handset enclosures)

Noise level: 54 dB(A) max (unloaded)
59 dB(A) max (maximum load capacity)

Environmental conditions:

	Operational Limits**	Transportation/Storage Limits
Ambient Temperature	0°C to 40°C	-10°C to 40°C
Relative Humidity	15% - 75%	10% - 90%
Atmospheric Pressure	73 kPa to 125 kPa	73 kPa to 125 kPa

Expected service life: 5 years*** (1 year for battery, charger, accessories)

** Always ensure the bath lift is brought to room temperature before plugging in or operating – Drive DeVilbiss Healthcare Ltd. recommends the bath lift is left for two hours or more to reach room temperature.

*** The service life of the bath lift and its components are dependent on it being serviced and maintained in accordance with section 13 of these instructions.

17. ACCESSORIES & SPARE PARTS

Service manuals and full lists of part codes are available from Drive DeVilbiss Healthcare Ltd. (see section 2).

	Product code
Accessories	
Mountway 'Corner and Wide Bath' Side Flap Kit (no screwdriver)	A164
Neptune Cushioned Cover Set	A244
Neptune Cushioned Cover – Seat	A240A
Neptune Cushioned Cover – Back	A241A
Large Pelvic Harness (Aquila/Neptune)	AB230
Slide & Swivel Aid	AB247
Side Flap Protector Extension Kit (1 protector + 2 clips)	AB284
Additional Extension Clips for Side Flap Protectors (x10)	AB285
Side Flap Protector Extension Kit (Non-Hooking)	AB287
Small Pelvic Harness with Gel Strap	5623-0216
Spare Parts	
Hinge and Screw Set (×4) for Side Flaps	A003
Single Hinge and Screw	A167
Actuator Snap Pin	1029-0034
Grey Neptune Support Block	1320-0105
Mountway A230.1 Battery Pack	5033-0007
Mountway Handset	5033-0009
Mountway CU3000 Smart Charger (UK)	5033-0010
TA8 Actuator (Splash/Neptune)	5535-0061
Suction Pad only	5037-0063



Warning

Only Drive DeVilbiss Healthcare approved accessories, specified for the Neptune bath lift, should be used — if in doubt, contact Drive DeVilbiss Healthcare Ltd. or your local distributor.

Drive DeVilbiss Healthcare cannot be held responsible for any injury or incident which relates to the use of any product combinations not approved by Drive DeVilbiss Healthcare Ltd. It is the carer's responsibility for selecting and fitting the products correctly and ensuring that the product combination is compatible.

18. WARRANTY

Drive DeVilbiss Healthcare Ltd. guarantees this product is free from defects in material and workmanship under normal use for 5 years (1 year for battery, charger and accessories, 2 years for consumable parts and 5 years for bath lift seat and frame only) from the date of purchase from Drive DeVilbiss Healthcare Ltd. and its subsidiary companies or its authorised dealers. All implied warranties, including but not limited to those implied warranties of fitness and merchantability, are limited in the total duration of 3 years from date of purchase.

DRIVE DEVILBISS HEALTHCARE LTD. MAKES NO OTHER WARRANTIES, EXPRESS OR IMPLIED, AND ALL IMPLIED WARRANTIES OF MERCHANTABILITY, NON-INFRINGEMENT AND FITNESS FOR A PARTICULAR PURPOSE ARE HEREBY DISCLAIMED. IN NO EVENT WILL DRIVE DEVILBISS HEALTHCARE LTD. BE LIABLE FOR PUNITIVE, SPECIAL OR CONSEQUENTIAL DAMAGES, OR FOR AN AMOUNT IN EXCESS OF THE PURCHASE PRICE OF THE DEFECTIVE DRIVE DEVILBISS HEALTHCARE LTD. PRODUCT OR PRODUCTS.

Proof of purchase must be presented with any claim. Except as provided herein, this warranty will not apply to any Drive DeVilbiss Healthcare Ltd. products that have been (a) damaged by lightning, water, or power surges, (b) neglected, altered, abused, or used for a purpose other than the purpose for which they were designed, (c) repaired by you or any other party without Drive DeVilbiss Healthcare Ltd. prior written authorisation, (d) used in conjunction with a third party product or products not approved in advance by Drive DeVilbiss Healthcare Ltd., (e) damaged or failed by or attributes to acts of God, (f) damaged, caused by failure to follow instructions, or (g) otherwise used in a manner inconsistent with any instructions provided by Drive DeVilbiss Healthcare Ltd. The warranty explicitly exempts consumable items.

This warranty contains the entire agreement between you and Drive DeVilbiss Healthcare Ltd. with respect to any warranty matters, and supersedes any and all other written or oral statements, representations or agreements relating to the subject matter of this warranty.

In the event of a product defect during the warranty period you should contact your supplier, whether it be Drive DeVilbiss Healthcare Ltd., its subsidiary companies, authorised dealers or international distributors who will at their option unless otherwise provided by law; a) correct the defect by product repair within the terms of the warranty b) replace the product with one of the same or similar design or c) refund the purchase price. All replaced parts and products on which a refund is made become the property of Drive DeVilbiss Healthcare Ltd. Repaired or replaced parts and products are warranted for the remainder of the original warranty period. You will be charged for repair or replacement of the product made after the expiration of the warranty period.

This limited 5-year warranty gives you specific legal rights and you may also have other rights.

Drive DeVilbiss Healthcare Ltd. cannot be held responsible for any injury or incident which relates to the use of this bath lift in conjunction with accessories manufactured by companies other than Drive DeVilbiss Healthcare Ltd.

Drive DeVilbiss Healthcare Ltd. has a policy of continual product improvement and reserves the right to amend specifications covered in this document.

No part of this document may be reproduced without the written approval of Drive DeVilbiss Healthcare Ltd.

drive

DeVilbiss
HEALTHCARE

CONTACT INFORMATION

Tel: +44 (0) 845 0600 333 Fax: +44 (0) 845 0600 334

Email: info@drivedevilbiss.co.uk

www.drivedevilbiss.co.uk

Drive DeVilbiss Healthcare Ltd., Sidhil Business Park,
Holmfield, Halifax, West Yorkshire, HX2 9TN, United
Kingdom

A member of the Drive DeVilbiss Group of Companies



ORIGINAL INSTRUCTIONS
8700-0007, 2024/03 — rev8